

Immunity measuring units Voltage-injection method

Immunity measurement of radio/TV broadcasting receivers and related equipment based on DIN57 872 (VDE 0872)

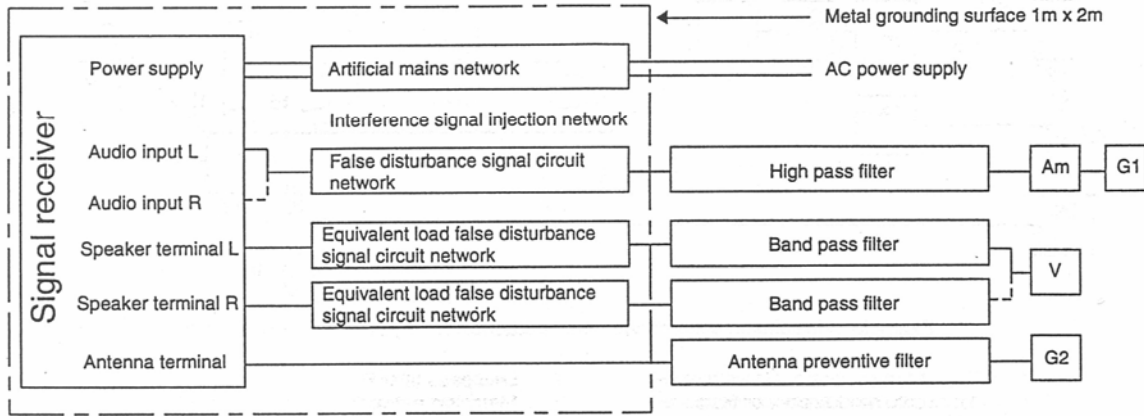

Example of immunity test measurement layout

G1 : Interference signal generator
G2 : Wanted signal generator

Am : Broadband power amplifier
V : Audio millivolt meter

High pass filter	KSI-1001	Band pass filter	KSI-1104
fc = 100kHz or 30MHz (Switchable)		fc = 500Hz ~ 3kHz	

* Types and quantities vary depending on the equipment under test.